

DIN5482

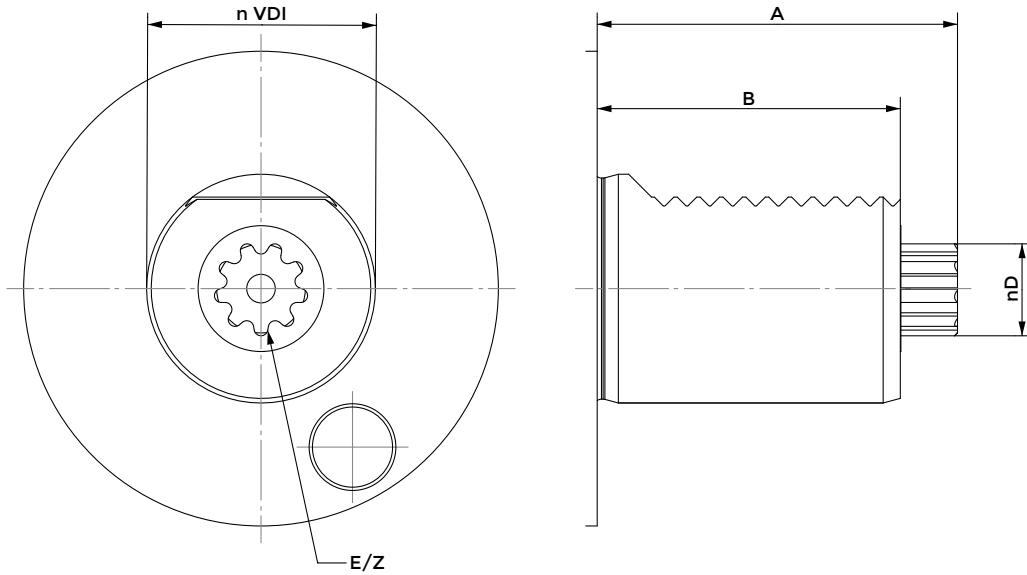

VDI	A	B	d	E	Z
30	55	45	14,5	B15X12	8
40	63	53	16,5	B17X14	9
50	93	78	19,5	B20X17	11

AXIAL DRILLING AND MILLING HEAD

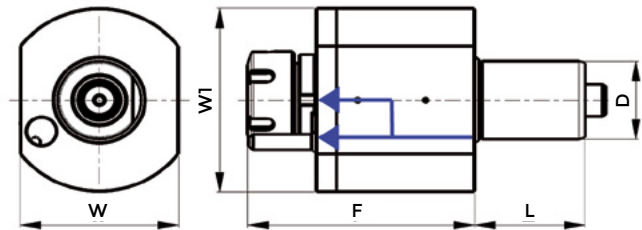
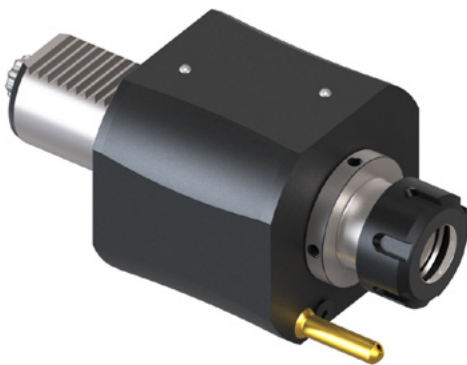

DIN5482 SAUTER

COD.	D	ER	INTERNAL COOLING	F	L	W	WI	MAX TORQUE (Nm)	MAX SPEED (Rpm)	RATIO	P Bar
116-43010	30	ER25	NO	87	45	64	68	28	6000	1:1	-
116-43011	30	ER25	YES	87	45	64	68	28	6000	1:1	20
116-44019	40	ER25	YES	105	53	80	86	50	6000	1:1	20
116-44020	40	ER32	NO	108	53	80	86	50	6000	1:1	-
116-44021	40	ER32	YES	108	53	80	86	50	6000	1:1	20
116-45013	50	ER40	YES	116,1	71	88	88	80	6000	1:1	20