

DIN5480

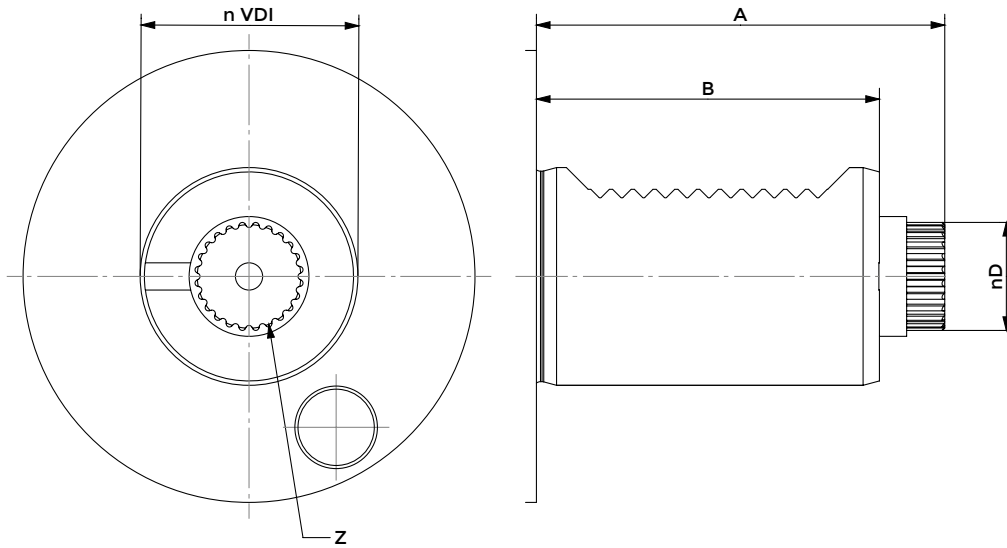

VDI	A	B	d	Z
30	67	55	15,8	18
40	75	63	19,8	24
50	93	78	23,8	18

AXIAL DRILLING AND MILLING HEAD

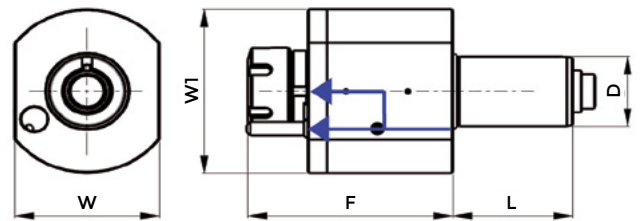
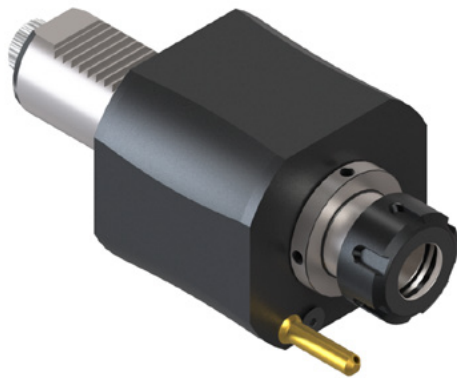

DIN5480 SAUTER

COD.	D	ER	INTERNAL COOLING	F	L	W	W1	MAX TORQUE (Nm)	MAX SPEED (Rpm)	RATIO	P Bar
116-43001	30	ER25	NO	87	55	64	68	28	6000	1:1	-
116-43002	30	ER25	YES	87	55	64	68	28	6000	1:1	20
116-44001	40	ER25	NO	105	63	80	86	50	6000	1:1	-
116-44002	40	ER25	YES	105	63	80	86	50	6000	1:1	20
116-44003	40	ER32	NO	108	63	80	86	50	6000	1:1	-
116-44004	40	ER32	YES	108	63	80	86	50	6000	1:1	20
116-45040	50	ER32	NO	114,1	78	88	88	80	6000	1:1	-
116-45041	50	ER32	YES	114,1	78	88	88	80	6000	1:1	20
116-45017	50	ER40	YES	116,1	78	88	88	80	6000	1:1	20