

## EXTENSION ADAPTOR WITH QUICK CHANGE POLYGONAL SHANK ACCORDING

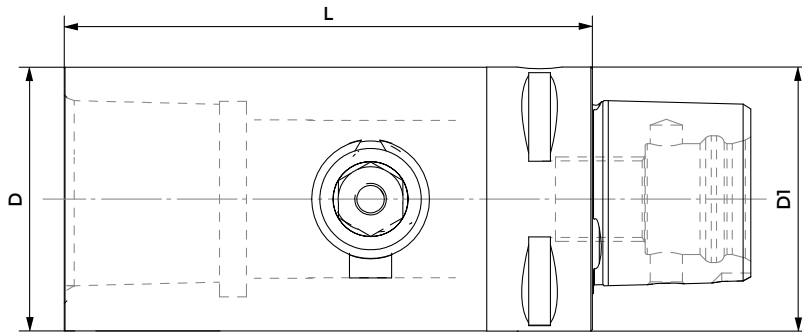

### DIN ISO 26623-1

COD.	POLYGONAL	SHANK	d	d1	L	MAX. (Rpm)
C40H85C40-CR	C40	C40	40	40	85	39000
C50H100C50-CR	C50	C50	50	50	100	28000
C63H115C63-CR	C63	C63	63	63	115	20000
C80H145C80-CR	C80	C80	80	80	145	14000

## REDUCTION ADAPTOR WITH QUICK CHANGE POLYGONAL SHANK ACCORDING

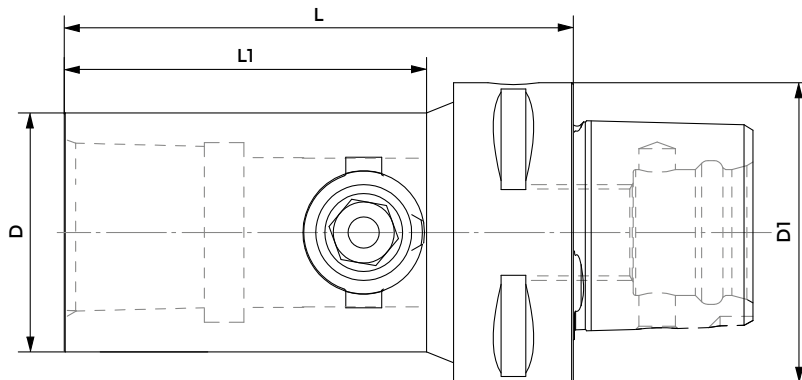

### DIN ISO 26623-1

COD.	POLYGONAL	SHANK	d	d1	L	L1	MAX. (Rpm)
C50H85C40-CR	C50	C40	50	40	85	60,5	28000
C63H100C50-CR	C63	C50	63	50	100	73	20000
C80H120C63-CR	C80	C63	80	63	120	84,5	14000

## INSTRUCTIONS TO CLAMPING TOOL HOLDER WITH QUICK CHANGE ADAPTERS WITH POLYGONAL SHANK ISO26623

TOOLSIDE	TORQUE (Nm)
PSC40	50Nm
PSC50	70Nm
PSC63	90Nm
PSC80	130Nm

